

060-1300 Flush Mount Security Latch



This redesigned security lock is intended for recreational vehicle entrance doors including motor homes and travel trailers where it is advantageous to use a remote mounted security lock. It features a serviceable KeyOne™ Plus lock cylinder, is power lockable and provides for easier installation.

DESIGNED FOR:

- Entrance door applications in travel trailers and motor homes with thicknesses of 1-1/2" (38.1mm) to 2-1/2" (63.5mm)
- Applications where it is desirable to use a remote mounted security lock

Global Locations:

TriMark Corporation
500 Bailey Avenue
P.O. Box 350
New Hampton, Iowa 50659
United States
Tel: 641-394-3188
Fax: 641-394-2392
1-800-447-0343
www.trimarkcorp.com

TriMark Europe
Cedar Court
Walker road
Bardon Hill
Coalville LE67 1TU
United Kingdom
Tel: +44(0)1530 512460
Fax: +44(0)1530 512461
www.trimarkeu.com

TriMark (Xuzhou)
Building A5 Jingwu Road
Xuzhou Economic
Development Zone
Xuzhou, Jiangsu
221004 PR China
Tel: +86 516 8773 0018
Fax: +86 516 8773 0058
www.trimarkcn.com



TriMark. Interactive. Product. Selector



TriMark



TriMark Corporation

FEATURES/BENEFITS:

- Can be mounted on either hollow or solid core door on travel trailers and motor homes
- Universal round design allows for use on left or right hand doors
- Dead bolt locks into the fully extended position for true dead bolt functioning
- Adaptable to powerlock actuation
- KeyOne™ Plus lock allows for serviceable lock cylinder

AVAILABLE:

- Keyed random with 100 key codes
- Standard 5-1/2" (139.7mm) backset
- Lock can be keyed to match other TriMark door products with KeyOne™ Plus for a single-key system, keyed alike or provided non-locking



INSTALLATION:

- Security lock sub-assemblies (3) are easy to install with supplied fasteners (inside and outside assemblies only)
- Supplied with gasket already applied under recess in housing flange for simple, clean installation

MATERIAL:

- Interior/exterior housing, lock knob and deadbolt - die cast zinc alloy
- Stamped steel deadbolt carrier

FINISH:

- Black powder coated or chrome
- Additional colors and finishes available – please inquire
- Zinc plated clear chromate steel components

Individual part dimensions are for reference only. Refer to individual part drawings for complete dimensions, specifications, and installation procedures. Engineering assistance and application drawings are available.

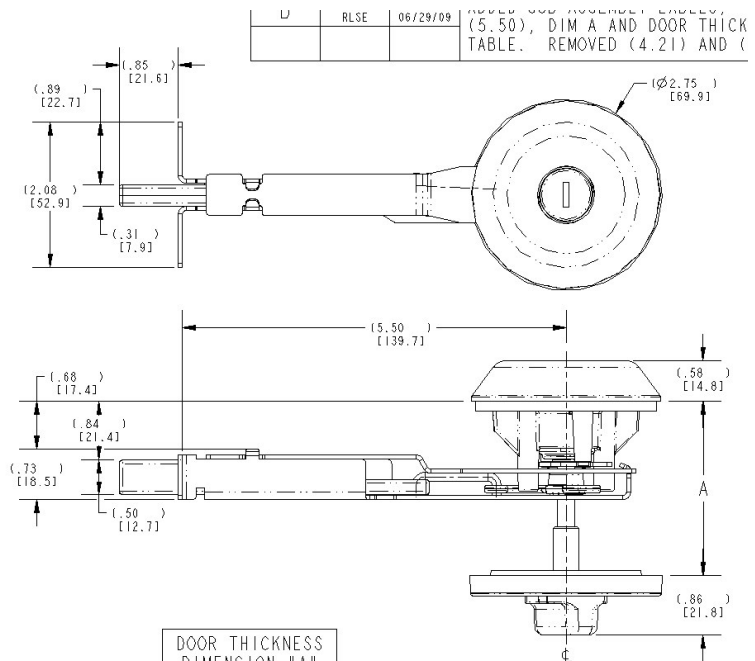
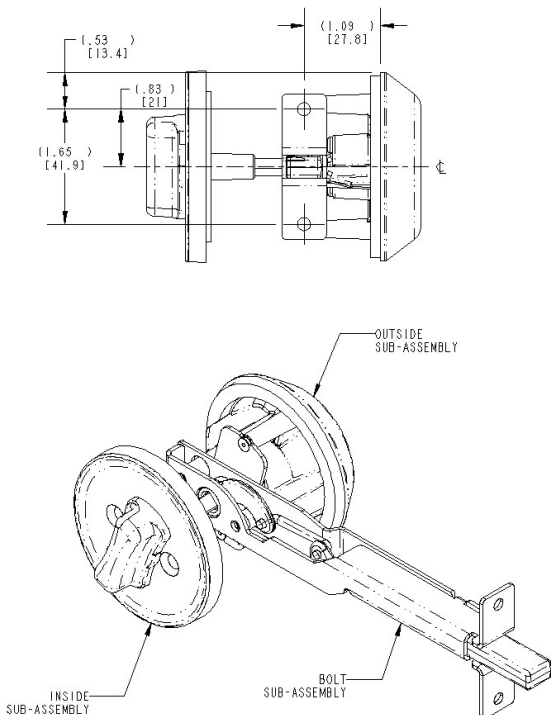

PRODUCT SUPPORT DRAWING
Individual part dimensions are for reference only. Refer to individual part drawings for complete dimensions and specifications.

For more information visit
www.trimarkcorp.com

